

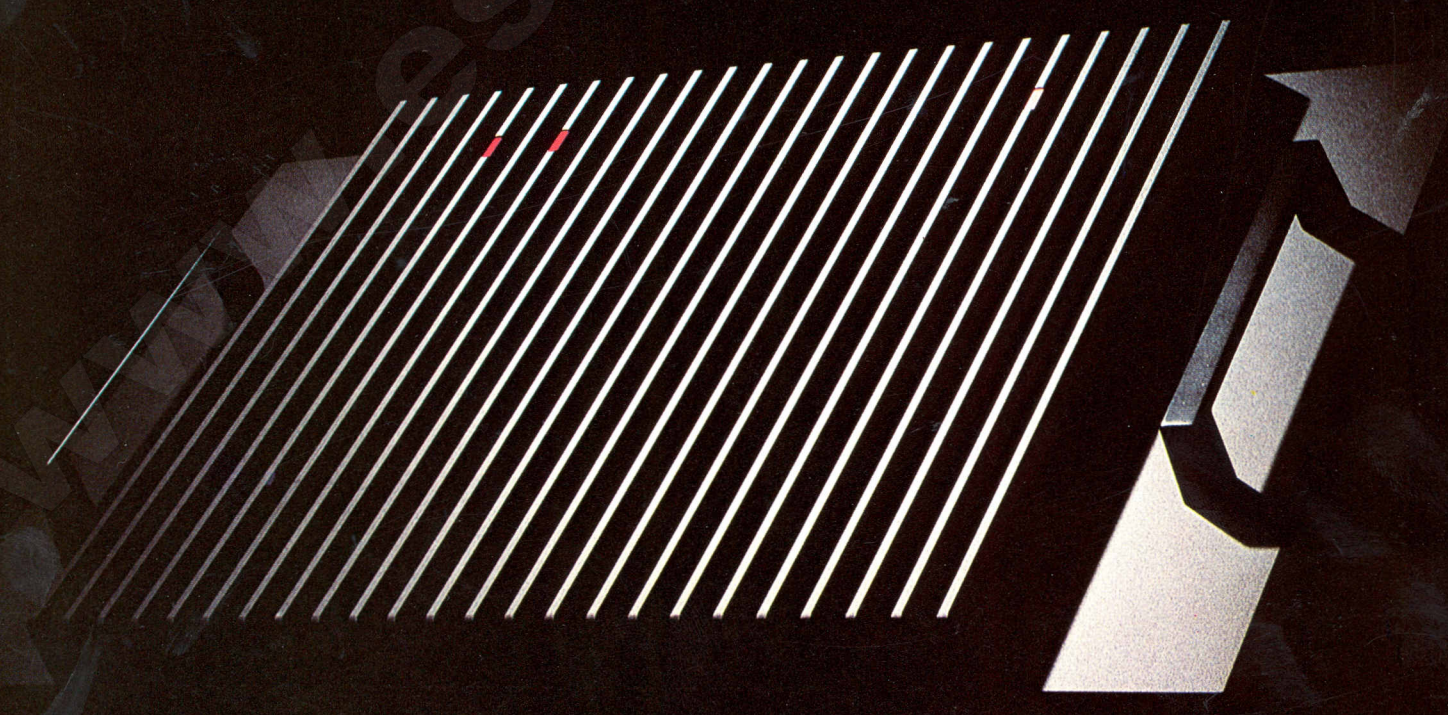

# Nakamichi 620

Power Amplifier

askoonline.nl



# THE NAKAMICHI 620 SETS NEW STANDARDS FOR POWER AMPLIFIER PERFORMANCE

TOTAL HARMONIC DISTORTION: LESS THAN 5 PPM(PARTS PER MILLION) AT 1 KHz AND ANY POWER LEVEL BETWEEN 1 AND 100 WATTS(8 OHM LOAD)

SIGNAL-TO-NOISE RATIO: BETTER THAN 120 dB(IHF-A)

POWER OUTPUT: 100 WATTS PER CHANNEL MINIMUM CONTINUOUS SINE WAVE, BOTH CHANNELS DRIVEN INTO 8 ohm LOADS, 5-20,000 Hz, WITH LESS THAN 0.01% THD

Research and engineering of the caliber that brought you the world famous Nakamichi cassette decks, now brings you a beautiful and unusual power amplifier, which, were it not for its power output, would be mistaken for a superb preamplifier. It should not be surprising that Nakamichi can develop such an incredible amplifier. Although much of the excellence of Nakamichi cassette decks can be attributed to

advanced magnetic head technology and sound mechanical engineering, none of it would have been possible without an extensive knowledge of low noise, low distortion solid state electronic circuitry. Over twenty years of close work with transistor circuits of far greater complexity than most preamplifiers and power amplifiers, have given Nakamichi Research an advantage that perhaps not even manufacturers spe-

cializing in electronics can match.

This advantage is clearly evident in the Nakamichi 620. Distortion is so low that a completely new method of measuring and stating THD had to be employed. Even the best distortion analyzers available today cannot give an accurate picture of the 620's distortion partially because the measurement is masked by noise, which, by the way, is more than 120 dB below rated output! The distortion specification was obtained with the aid of a Bruel and Kjaer model 3348 Real Time Analyzer. 5PPM(parts per million) is equivalent to 0.0005%, and at these very low levels PPM becomes a more practical way of stating distortion than per cent.

The 620 contains circuitry not found in any other power amplifier. Nakamichi's COMPLETE MIRROR push-pull circuitry delivers performance unlike any other full-complementary design. The 620's ample power output backed by a power supply of tremendous reserve capacity, assures ultra-clean reproduction even with low efficiency loudspeakers.

## COMPLETE MIRROR PUSH-PULL CIRCUITRY

Nakamichi's COMPLETE MIRROR design brings a level of performance to class B amplifiers that was formerly associated only with class A amplifiers. The 620 is closer to a pure class B amplifier than anything else that has gone before. The first stage of the 620 is a differential amplifier with "current mirror" loading. The final section of the amplifier is a four stage push-pull circuit. All four stages are full complementary direct coupled, and each stage employs a unique double NPN/PNP combination for the positive and negative halves. This design eliminates the errors inherent in even the most carefully matched pairs of NPN/PNP output devices. These errors, furthermore, are eliminated without the use of bias diodes, bias adjustments and high idle currents. The 620, in fact, idles at approximately 1/20 the current of conventional class B power amplifiers of comparable output power. The diagram illustrates the perfect symmetry between the positive and negative halves of the output stages (thus the name COMPLETE MIRROR). This new approach takes full advantage of class B efficiency with the freedom from switching and crossover distortions that was once thought possible only with class A amplifiers.

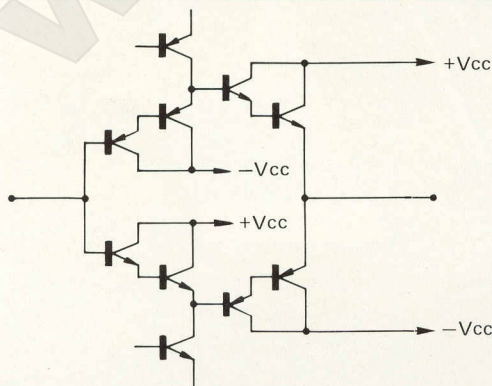
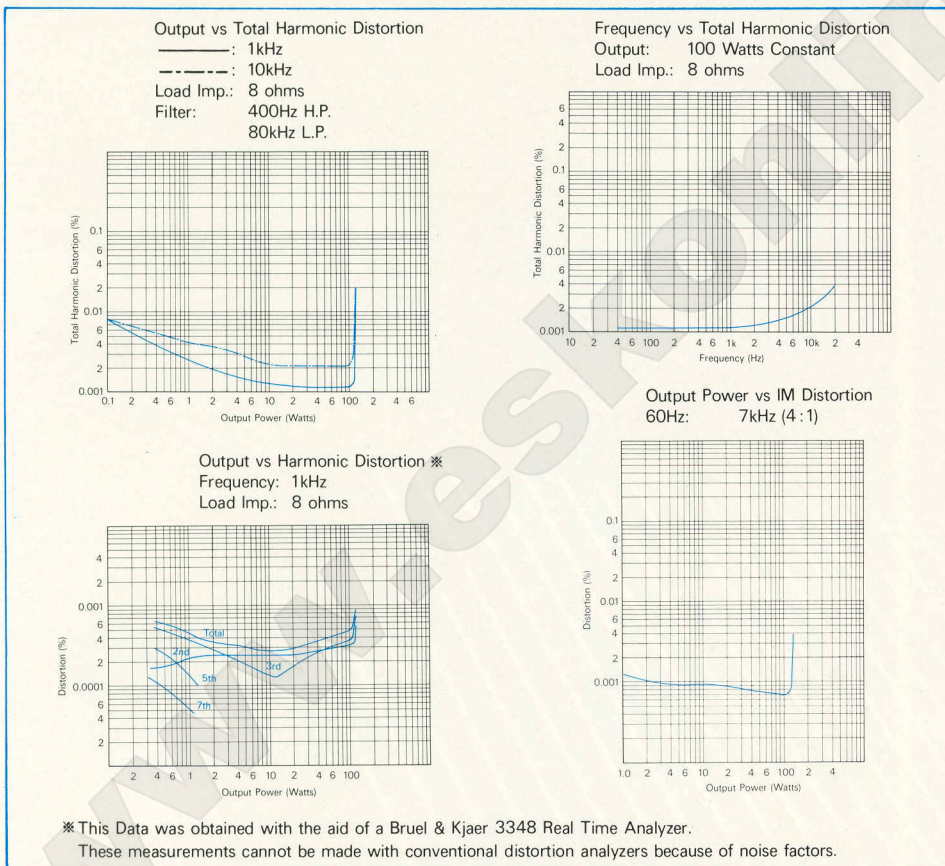

Nakamichi 620 output section circuitry

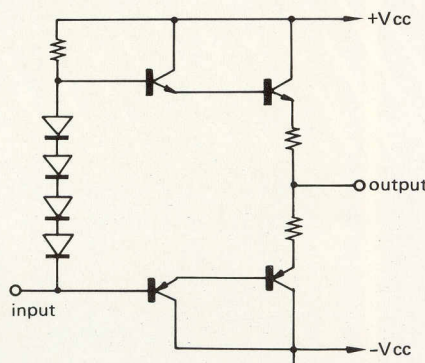

Conventional push-pull output section circuitry

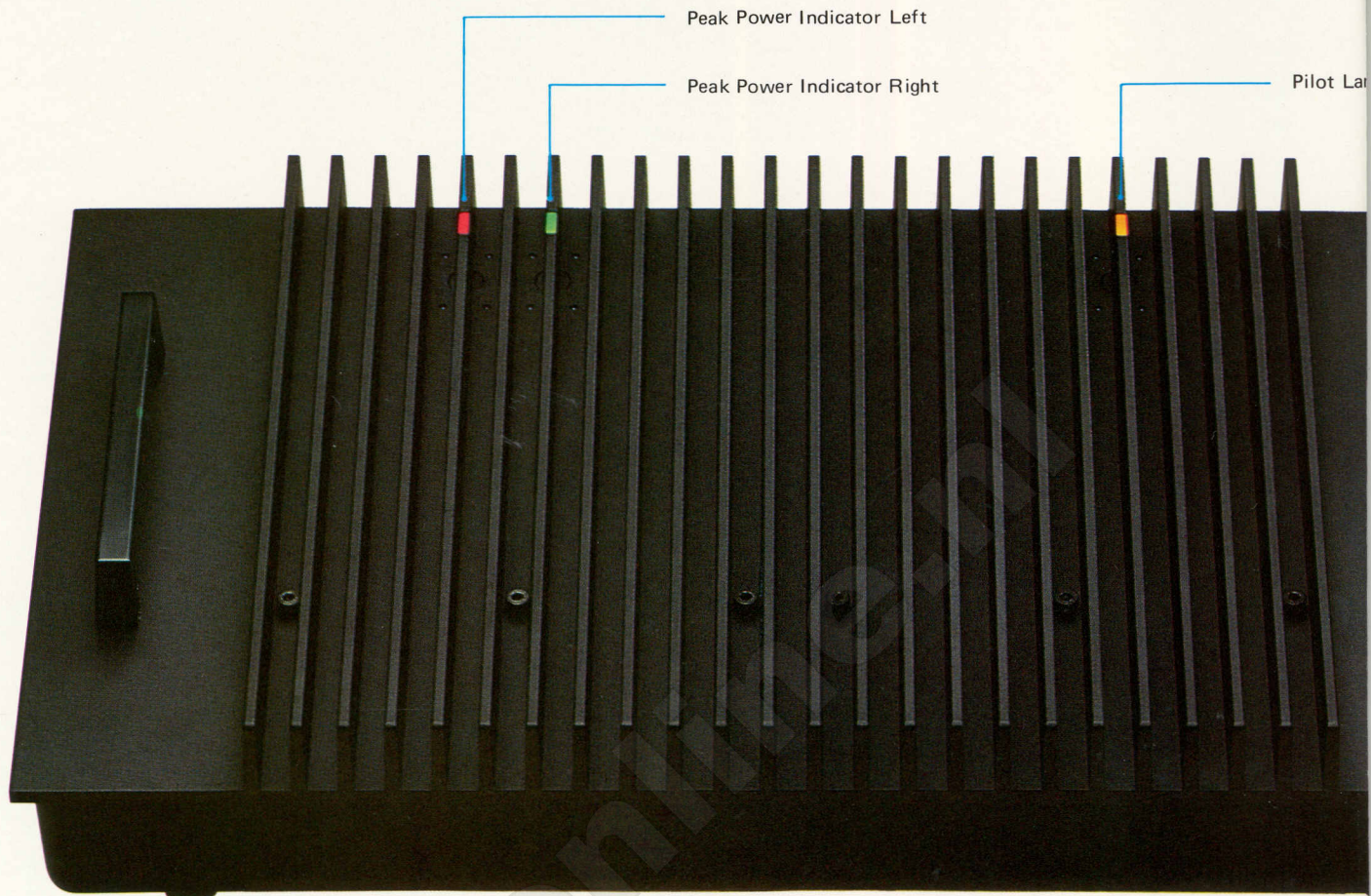

## LOW TEMPERATURE — HIGH STABILITY

The relatively low idle current in the Nakamichi 620 is responsible for its low operating temperature. Under normal use, the heat sink fins always remain cool to the touch. Low operating temperature helps maintain a low residual noise level (under 0.05 mV, IHF-A). It also minimizes the possibility of output transistor failure caused by thermal runaway. Since the 620 does not utilize conventional temperature compensation circuitry, performance stability and predictability is extremely high. Most class AB type amplifiers require a lengthy warm-up period before reaching their lowest distortion levels. The 620, however, thanks to more efficient use of push-pull circuitry, provides full specification performance from the instant power is turned on.

## HIGH CAPACITY SINGLE POWER SUPPLY

The 620's mammoth power supply occupies over half of the available space inside. A large toroidal core power transformer with current handling capability equalling conventional units many times its size is filtered by two 40,000 microfarad capacitors. The power supply is capable of such enormous reserve that there is no appreciable difference between performance with one channel driven and that with both channels driven. Nakamichi has intentionally avoided the use of two independent power supplies, one for each channel. Although double power supplies are becoming increasingly popular, careful study has demonstrated the clear superiority of a well-designed single power supply. The single power supply in the Nakamichi 620 is grounded firmly by a copper block

without the use of solder to ensure zero resistance with respect to the chassis. Research has shown that for any given cost and cabinet size, a single power supply outperforms two independent supplies in the areas of regulation and overload recovery.

## LOW NEGATIVE FEEDBACK

Many recent power amplifier designs rely on large amounts of negative feedback to reduce harmonic distortion. The disadvantages of such a design generally are "harsh" clipping (amplifier overload) and increased transient intermodulation distortion. The 620's open loop total harmonic distortion (without negative feedback) is under 0.05% at full power! The result of this sound design philosophy is virtually undetectable amplifier overload.

## UNCONDITIONAL LOAD STABILITY

Many amplifiers become unstable when presented with an unusual load, such as an electrostatic loudspeaker. Some amplifiers even suffer from the capacitance in speaker wire. The 620 has been fully tested into all types of reactive loads. The oscilloscope photograph below shows the near absence of overshoot when the 620 is connected to a complex load, a remarkable feat for any type of amplifier.

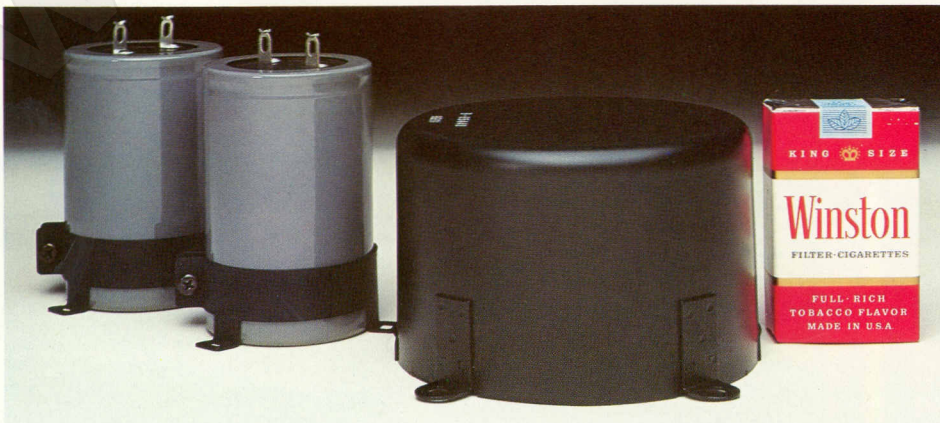



# Nakamichi 620

Power Amplifier

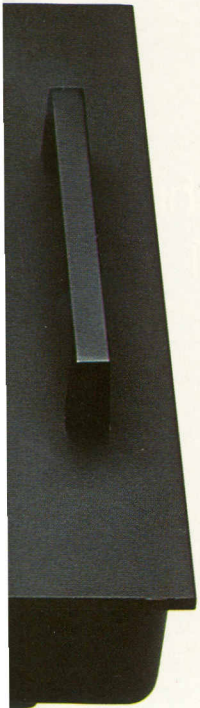

## PEAK POWER INDICATORS

Inset into the heat sink fins of the 620 are two peak power indicating lamps, one for each channel. These lamps are a part of a special circuit that is able to react to pulses as short as 0.1 millisecond. When such a pulse occurs, the lamps will stay lit for 0.3 second so that the peak power indication is clearly visible. The lamps may be preset by rear panel switches so that they glow green at 1, 5 or 25 watts, and red at 25, 50 or maximum watts (reference: 8 ohm load). When both green and red are set for 25 watts indication, only the red will operate. When the red threshold switch is set for "max," the lamps become accurate indicators of the true clipping point for each channel, adjusting for variations in line voltage, signal frequency and load impedance.

## PROTECTION CIRCUITRY

Although the 620's power transistors are operated well within their safe areas, a unique current controlling circuit protects the amplifier from short circuits and other failures. Unlike most current limiters, which tend to activate prematurely, the protection circuit in the 620 senses both voltage and current. The circuit is so foolproof that it never interferes with normal operation of the amplifier; its effectiveness is witnessed by the fact that the 620 can withstand a short circuit almost indefinitely. Relays and circuit breakers have been avoided in the output stages as all these devices are slightly non-linear.

620 performance verification with the Bruel and Kjaer 3348 Real Time Spectrum Analyzer and Sound Technology 1700B Distortion Analyzer

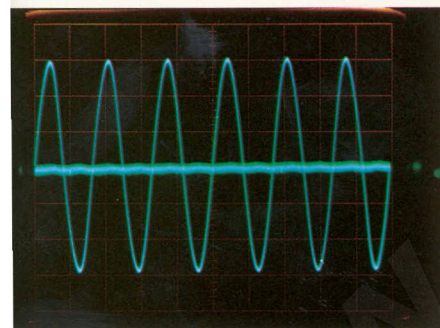

frequency: 1kHz  
H.D./Noise 0.0011%

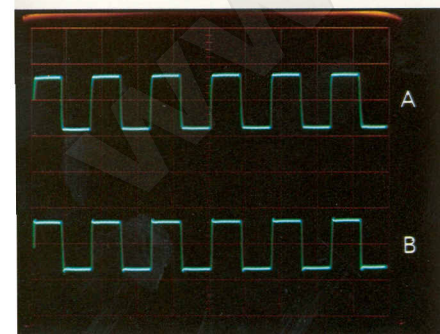

1kHz Square wave  
A... Load: 8 ohms  
B... Load: 0.1µF//8 ohms

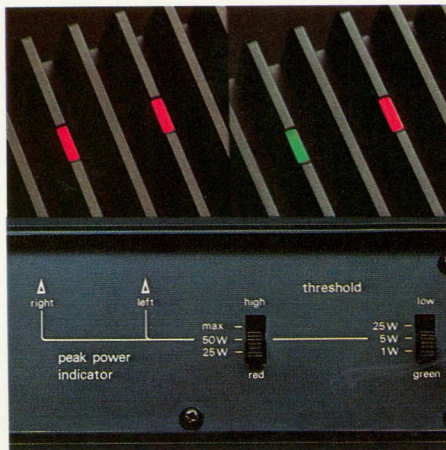

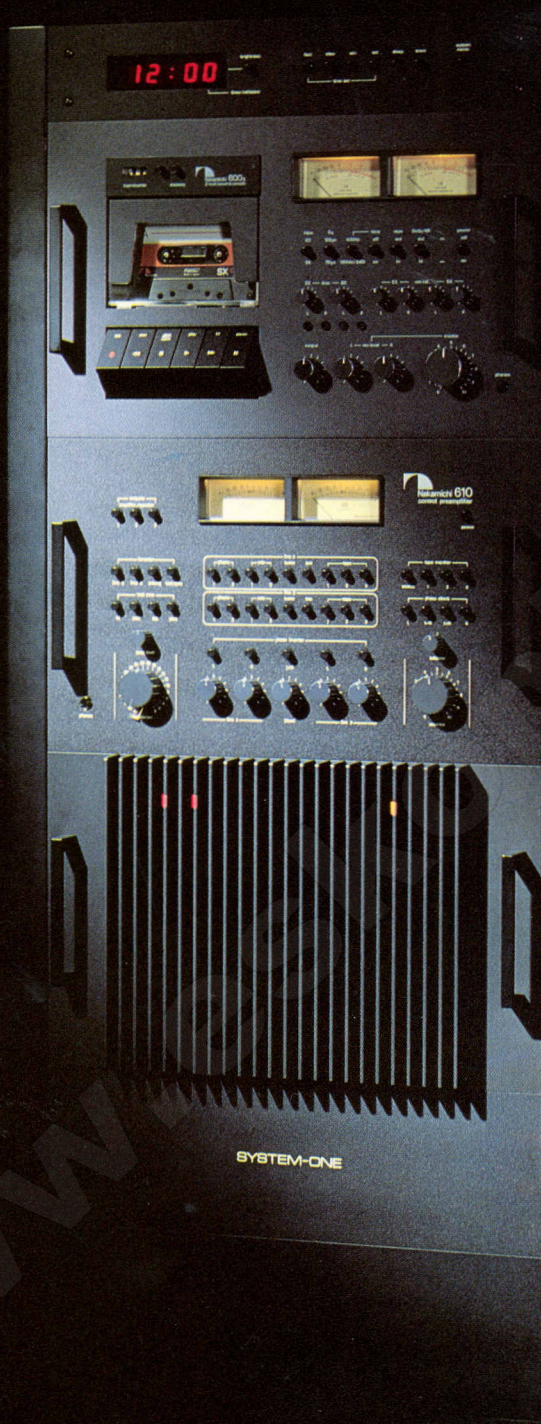

## Nakamichi SYSTEM-ONE

The Nakamichi 600 Series was originally envisioned as a group of components that would allow the creative audiophile a degree of flexibility and control in the recording and reproduction of music never before available on consumer high fidelity equipment. With the introduction of the 620, Nakamichi is also making available a custom rack mount for the 600 Series components. Designated the SYSTEM ONE, this strikingly attractive module consists of the Model 600II Cassette Console, the Model 610 Control Pre-amplifier, the Model 620 Power Amplifier, and a unique multi-function digital program timer. Differing in basic concept from the currently fashionable 19 inch standard rack mount components, the Nakamichi SYSTEM ONE offers a decidedly non-industrial appearance. It will serve as the nucleus around which a high accuracy creative music system can be built.

## Nakamichi 620 Specifications

Power Source	100/117/220/240 V AC, 50/60 Hz
Power Consumption	50 VA at idling 700 VA with both channels driven to clipping into 8 ohm loads
Power Output	100 Watts per channel minimum continuous sine wave ("RMS") at 8 ohms. 5 – 20,000 Hz with less than 0.01% THD 50 Watts per channel at 16 ohms
IHF Power Bandwidth (both channels driven)	5 – 50,000 Hz for less than 0.1% THD 5 – 20,000 Hz for less than 0.01% THD 5 – 10,000 Hz for less than 0.005% THD
Damping Factor	Greater than 100 (1 KHz, 8 ohms)
Total Harmonic Distortion	Less than 0.002% @ 1 KHz or below Less than 0.005% @ 10 KHz or below
Intermodulation Distortion	Less than 0.002% (60 Hz: 7 KHz, 4:1, 8 ohm load, 100 W output)
Frequency Response	5 – 100,000 Hz +0, -1 dB
Input Sensitivity	1 Volt
Input Impedance	10 K ohms
Residual Noise Level	Less than 0.05 mV (IHF A Network) Less than 0.1 mV (linear)
Signal-to-Noise Ratio	Better than 120 dB at rated output (IHF A, input shorted)
Crosstalk	Better than -70 dB @ 1 KHz
Peak Power Indicators	Green at 1 W, 5 W, 25 W, selectable Red at 25 W, 50 W, Maximum (110 – 130 W) selectable (Response time: responds to 0.1 ms pulse – off after 0.3 sec)
Semiconductor Complement	Integrated Circuits: 3 Transistors: 46 Diodes: 41
Dimensions	15.75"(W) x 7.44"(H) x 9.76"(D) 400 mm(W) x 189 mm(H) x 248 mm(D)
Weight	27.6 lb (12.5 kg)



600II Black Version



610 Black Version



●OPTIONAL ACCESSORY  
600 Series Walnut Grain Cabinet

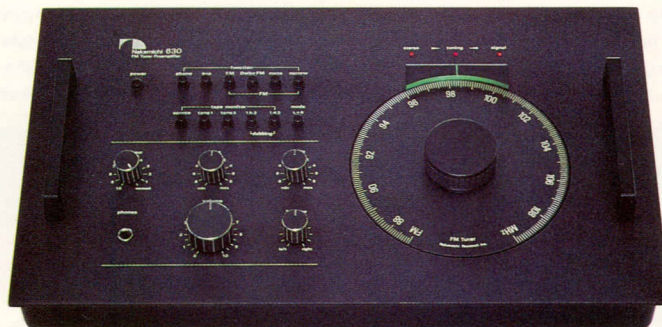

FM Tuner Preamp 630

### Nakamichi Research Inc.

1-153 Suzukicho, Kodaira, Tokyo  
Phone: (0423) 42-1111  
Telex: 2832610 (NAKREI J)  
Cable: NAKAMICHI KOKUBUNJI

### Nakamichi Research (U.S.A.), Inc.

220 Westbury Avenue  
Carle Place, N.Y. 11514  
Phone: (516) 333-5440  
Telex: 144513 (NAKREI CAPL)

### Nakamichi Research (U.S.A.), Inc.

1101 Colorado Avenue  
Santa Monica, Calif. 90401  
Phone: (213) 451-5901  
Telex: 652429 (NAKREI SNM)